

Physics without Causality - Theory and Evidence

Richard Shoup
Thomas Etter

Boundary Institute
Los Altos, California, USA

shoup@boundary.org

Copyright © 2006 - All Rights Reserved

Overview

- Introduction, the problem
- Quantum Entropy
- Unitary Measurement
- Randomness, RNG network
- Experiments, evidence
- Summary



Shoup & Etter - AAAS, June '06

Boundary Institute

Q & A

- Unanswered Questions
 - Can the future influence the present?
 - Does God play dice?
 - How does Psi work?
- Unquestioned Answers
 - Cause-and-Effect principle?
 - Quantum Measurement “collapse”?
 - Fundamental randomness?

Shoup & Etter - AAAS, June '06

Boundary Institute

Motivations

- Explain certain anomalous phenomena
 - Precognition, PK, RNG deviations, etc.
 - Implications for science, society
- Make sense of Quantum Mechanics
 - Interpretations, formalism
 - Reconsider “collapse”, fundamental randomness
- Arrow of time, time travel, free will, etc.

"I've got some grad student. He's thinking about the meaning of quantum mechanics. He's doomed." -- John McCarthy

Shoup & Etter - AAAS, June '06

Boundary Institute

Psi Impossible??

"Your belief system is shot."



"Needless to say, [paranormal phenomena such as precognition] would be just as upsetting in quantum mechanics as in classical physics; If genuine, they would require a complete revamping of the laws of nature as we know them."

-- Murray Gell-Mann, The Quark and the Jaguar

Shoup & Etter - AAAS, June '06

Boundary Institute

Hypothesis

- Complete time symmetry
 - Preparation is symmetric with measurement
 - Present can influence future and past "histories"
 - (But radioactive decay, black holes, kaons, ZPF?)
- All is unitary, including measurement
 - No "collapse" of the wavefunction
 - No fundamental randomness
 - Backward influence possible & necessary

Shoup & Etter - AAAS, June '06

Boundary Institute

What About Causality?

- Common sense - cause *before* effect, unidirectional??
- Laws of physics are time-symmetric
 - Exception?: random "collapse" of the wavefunction
- Causality => *influence, dependence, correlation*
- Bidirectional *relations*, not functions
- Bidirectional connections (*links*), not inputs or outputs

"All philosophers imagine that causation is one of the fundamental axioms of science, yet oddly enough, in advanced sciences ... the world 'cause' never occurs.... The law of causality, I believe, ... is a relic of a bygone age, surviving, like the monarchy, only because it is erroneously supposed to do no harm."

-- Bertrand Russell, 1913

Shoup & Etter - AAAS, June '06

Boundary Institute

Cause => Relation

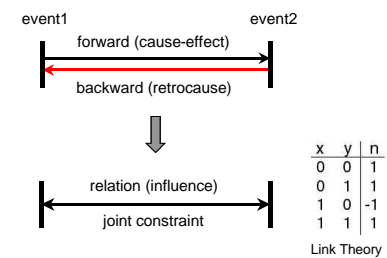

"An elementary particle is not an independently existing, unanalyzable entity. It is, in essence, a set of relationships that reach outward to other things."

-- Henry Stapp

Shoup & Etter - AAAS, June '06

Boundary Institute

Time Symmetry

Classical $E = \frac{1}{2}mv^2 = \frac{1}{2m}p^2$

substituting $E \rightarrow i\hbar \frac{\partial}{\partial t}$ and $p \rightarrow i\hbar \frac{\partial}{\partial x}$ gives

Quantum $i\hbar \frac{\partial \Psi(x,t)}{\partial t} = -\frac{\hbar^2}{2m} \frac{\partial^2 \Psi(x,t)}{\partial x^2}$

A solution for $+t$ is also a solution for $-t$.

Shoup & Etter - AAAS, June '06

Boundary Institute

Quantum Dynamics

1. Unitary evolution

(Schrödinger equation)

- linear, unitary, conservative, reversible, deterministic

2. Measurement ("collapse" of the wavefunction)

- non-linear, non-unitary, non-conservative, non-reversible, random, unpredictable

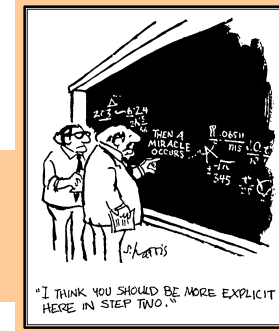

Shoup & Etter - AAAS, June '06

Boundary Institute

Entropy

Classical $H(A) = -\sum_a p(a) \log_2 p(a)$

Quantum $S(A) = -\text{Tr}_A[\tilde{\rho}_A \log_2 \tilde{\rho}_A]$

where $\tilde{\rho}_A$ is the density operator, and Tr_A is the trace over A.

Shoup & Etter - AAAS, June '06

Boundary Institute

Quantum Entropy

	$S_{A B}$	$S_{A:B}$	$S_{B A}$	$S_A=S_B$	S_{AB}
classical (independent)	1	0	1	1	2
classical (correlated)	0	1	0	1	1
quantum (entangled)	-1	2	-1	1	0

after Cerf & Adami, 1995

Shoup & Etter - AAAS, June '06

Boundary Institute

Quantum Dense Coding

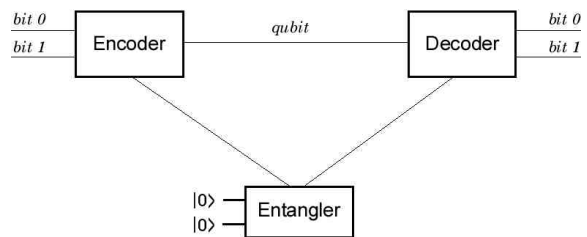

Shoup & Etter - AAAS, June '06

Boundary Institute

Quantum Teleportation

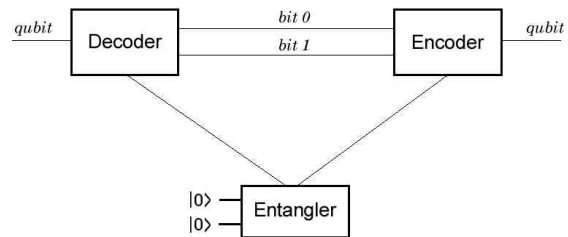

Shoup & Etter - AAAS, June '06

Boundary Institute

Quantum Measurement

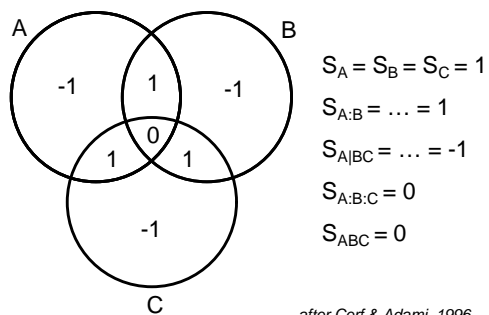

after Cerf & Adami, 1996

Shoup & Etter - AAAS, June '06

Boundary Institute

Quantum Measurement

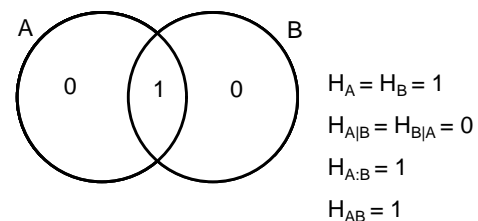

after Cerf & Adami, 1996

Shoup & Etter - AAAS, June '06

Boundary Institute

Measurement Interaction

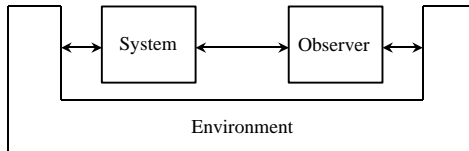

Shoup & Etter - AAAS, June '06

Boundary Institute

Randomness vs. Backward Influence

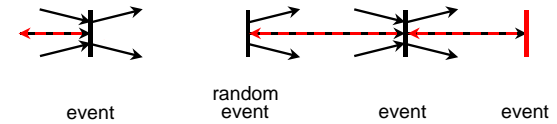

Shoup & Etter - AAAS, June '06

Boundary Institute

REG/RNG: Uninfluenceable, Unpredictable

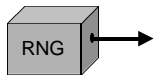

- No inputs
- No memory

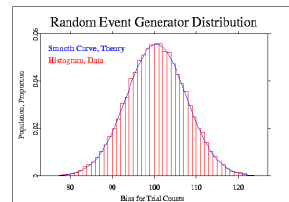

Tests: Diehard, NIST, Comscire, etc.

Shoup & Etter - AAAS, June '06

Boundary Institute

Is Nature Probabilistic?

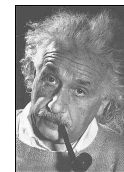

"[QM] yields much, but it hardly brings us closer to the Old One's secrets. I, in any case, am convinced that He does not play dice."
- A. Einstein, letter to Max Born, 1924

"Not only does God definitely play dice, but He sometimes confuses us by throwing them where they can't be seen."

- S. Hawking, 1995

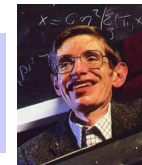

Shoup & Etter - AAAS, June '06

Boundary Institute

What About the 2nd Law?

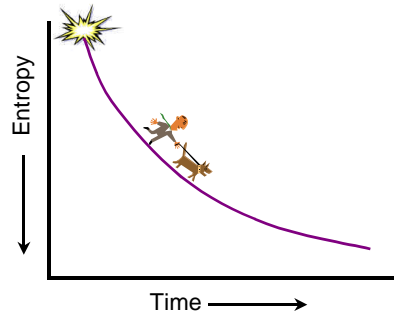

Shoup & Etter - AAAS, June '06

Boundary Institute

Electronic Randomness



→ ... 0 1 1 0 1 0 0 1 0 0 0 1 1 1 ...

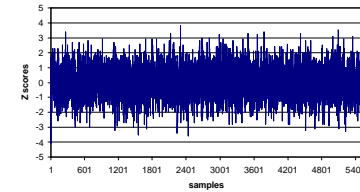

Shoup & Etter - AAAS, June '06

Boundary Institute

Global Consciousness Project

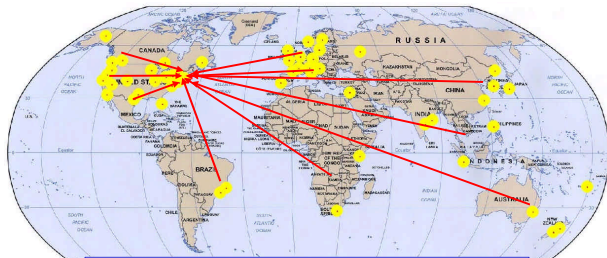

>70 true-random RNGs around the world
 200 bits / sec / RNG = >1 Gb / day
<http://noosphere.princeton.edu>

Shoup & Etter - AAAS, June '06

Boundary Institute

Anomalous Behavior in the GCP network of Random Generators on September 11, 2001

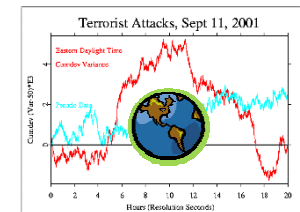

Shoup & Etter - AAAS, June '06

Boundary Institute

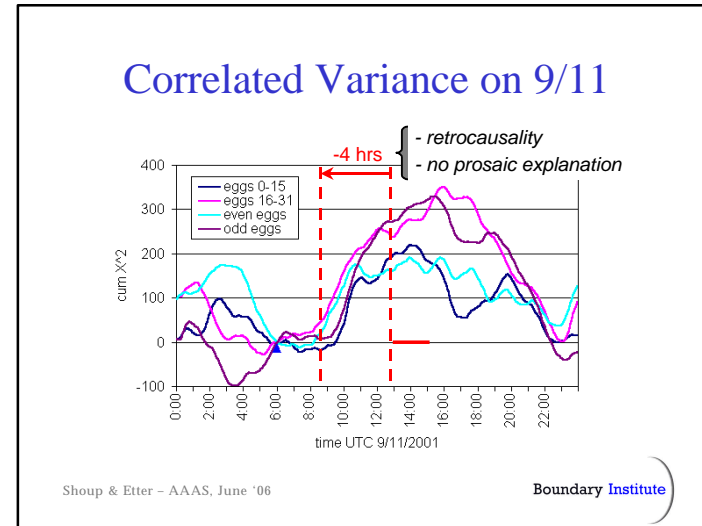
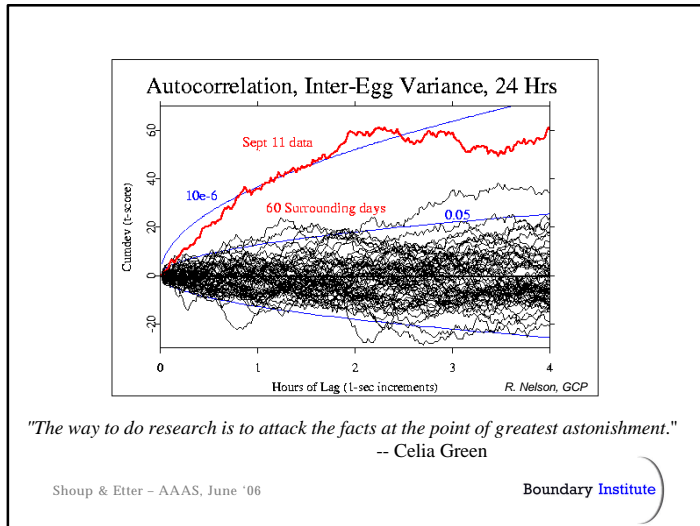



FOUNDATIONS OF PHYSICS LETTERS
VOL. 15, NO. 6, DECEMBER 2002

**CORRELATIONS OF CONTINUOUS RANDOM DATA
WITH MAJOR WORLD EVENTS**

R. D. Nelson,^a D. I. Radin,^b R. Shoup,^c P. A. Bancel^d

^a*Department of Mechanical and Aerospace Engineering
Princeton University
Princeton, New Jersey, 08544, USA,
E-mail: rdnelson@princeton.edu*

^b*Institute of Noetic Sciences, Petaluma, California, 94952*

^c*Boundary Institute, Los Altos, California, 94024*

^d*108, rue St Maur, Paris, France F-75011*

Received 18 July 2002; revised 4 October 2002

The interaction of consciousness and physical systems is most often discussed in theoretical terms, usually with reference to the epistemological and ontological challenges of quantum theory. Less well known is a growing literature reporting experiments that examine the mind-matter relationship empirically. Here we describe data from a global

Shoup & Etter - AAAS, June '06 Boundary Institute

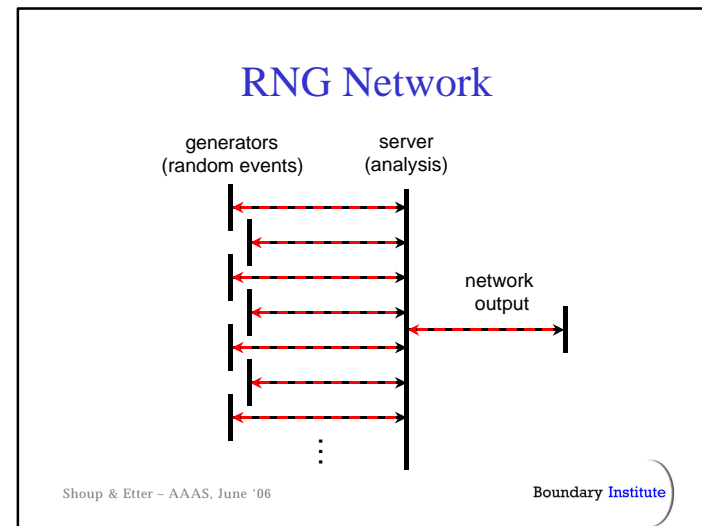

Origin of Randomness?

- RNG is best thought of as an *empty box*
 - Not a generator, but a *receiver*
 - No such thing as causeless action
 - Reflection of *outputs* connected to it
 - Output *appears* random due to many dependents
- Effects can be understood *without* a lot of new physics
 - Measurement is *unitary* -- no “collapse”
 - Influence forward and backward (*relational*)
 - Events are connected through *past* or *future* interactions

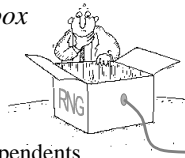

Shoup & Etter – AAAS, June '06

Boundary Institute

Physics vs Parapsychology

- Parapsychology is a respectable science
 - Parapsychological Association - AAAS member since 1969
 - Peer-reviewed journals: JP, JASPR, JSPR, EJP, JSE, others
 - Controlled laboratory experiments, repeatable
 - telepathy, clairvoyance, precognition, psychokinesis
 - NOT fortune-telling, UFOs, bigfoot, etc, etc.
- But we're doing *physics*
 - Anomalies (cf. Michelson-Morley, perihelion of Mercury, etc, etc.)
 - New foundations of Quantum Mechanics, and more
 - New foundations for mathematics, computer science

"I like to keep an open mind, but not so open my brains fall out."
-- Arthur Sulzberger, Chairman, New York Times

Shoup & Etter – AAAS, June '06

Boundary Institute

Key Anomaly: Psi

- Abundant evidence, yet little acceptance
 - Independent replications, peer-reviewed journals, etc.
 - Meaningful experiments and analysis are *very* difficult
 - Risk of ridicule, pseudo-skeptics, etc.
 - Disrepute due to “new age” wishful thinking about QM
- No adequate theory, phenomena *appear* to contradict physics
 - Really only our interpretations, misunderstandings?
 - New forces, fields, particles, dimensions, etc., required?
 - Cause-and-Effect thinking deeply ingrained
- Small statistical effects, not easily repeatable

"I shall not commit the fashionable stupidity of regarding everything I cannot explain as a fraud." -- C. G. Jung, 1919

Shoup & Etter – AAAS, June '06

Boundary Institute

Key Anomaly: Psi - II

- Traditional taxonomy inappropriate, misleading
 - Telepathy, Clairvoyance, Precognition, Psychokinesis
 - Likely different aspects of the same natural phenomenon
- Important properties (*hints*), from the *evidence*
 - Time/order independence (clairvoyance vs precognition)
 - Complexity independence (goal orientation)
 - Selectivity problem (sensing & affecting)
 - Experimenter effect (belief, audience)
 - Effect small (in principle?), unavailable to evolution
- Real physical phenomena, poorly understood
 - Not poor technique or analysis, fraud, hallucination, etc.
 - Analogy to electromagnetism

Shoup & Etter – AAAS, June '06

Boundary Institute

Simple Experiment

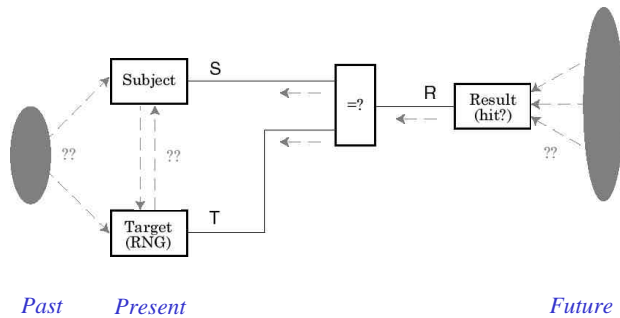

Past Present

Future

Shoup & Etter – AAAS, June '06

Boundary Institute

Constraints on the Future

- Backwards influence from results
- Equivalent to regarding the outcome afterwards
- Not new – Etter, Schmidt, Bierman, von Lucadou, etc.
 - Etter, Thomas, and Noyes, H. Pierre, “Process, System, Causality, and Quantum Mechanics”, *Physics Essays*, 1999.
 - Schmidt, Helmut, “Can an Effect Precede Its Cause? A Model of a Noncausal World”, *Found. Physics*, 1978.
 - Etter, Thomas, “On the Occurrence of Some Familiar Processes Reversed in Time”, 1960.

Shoup & Etter – AAAS, June '06

Boundary Institute

Boundary Institute

Welcome to the Boundary Institute's on-line psi tests



Card Test



Remote Viewing Test



Sequential Card Test



Location Test

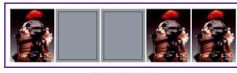

Card Draw Test

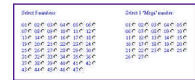

Lottery Test

www.boundarylab.org
www.gotpsi.org

Shoup & Etter – AAAS, June '06

Boundary Institute

Card Guessing

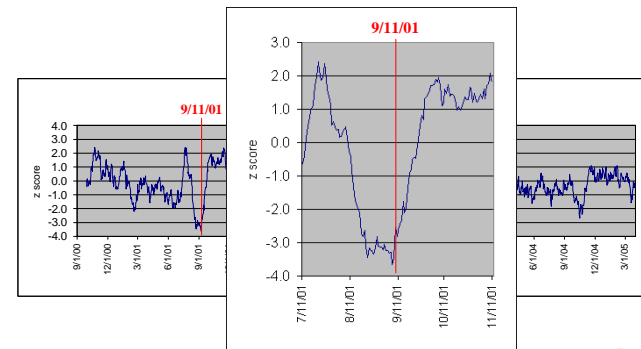

Shoup & Etter – AAAS, June '06

Boundary Institute

Simple Experiment w offsets

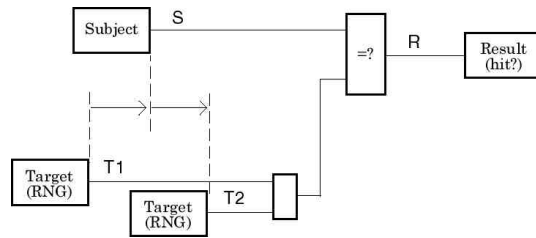

Shoup & Etter - AAAS, June '06

Boundary Institute

Card Guessing - T1 vs T2

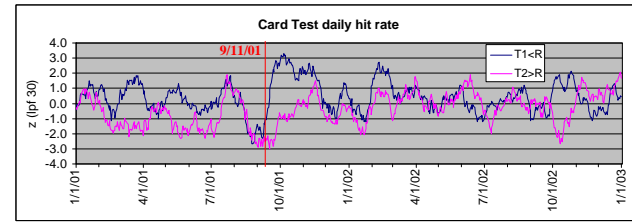

Shoup & Etter - AAAS, June '06

Boundary Institute

Influencing the CT Targets?

Card Test - User AH, 1/14/06, total 1201 trials, 284 hits (23.6%), $p = 1/921$

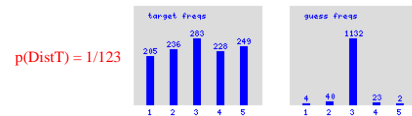

Card Test - User AH, 3/23/06, total 820 trials, 204 hits (24.9%), $p = 1/2599$

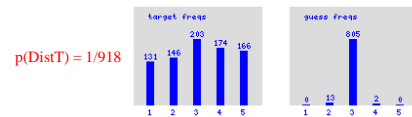

Shoup & Etter - AAAS, June '06

Boundary Institute

Influencing the QRV Targets?

QRV Test - User AH, 8/26/05, total 450 trials, 112 hits (24.9%), $p = 1/150$

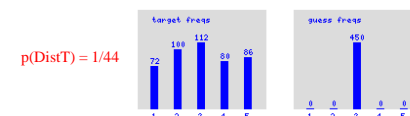

QRV Test - User AH, 9/11/05, total 710 trials, 169 hits (23.8%), $p = 1/136$

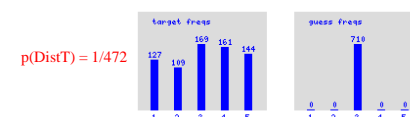

Shoup & Etter - AAAS, June '06

Boundary Institute

Theory redux

- Allows backwards cause/influence
 - Modest changes to quantum theory formalism, simpler
- Good agreement/explanation for psi properties (hints)
 - Time/order independence (clairvoyance vs precognition)
 - Complexity independence (goal orientation)
 - Selectivity problem (sensing & affecting)
 - Experimenter effect (belief, audience)
 - Effect small (in principle?), unavailable to evolution, etc

Shoup & Etter – AAAS, June '06

Boundary Institute

Summary Q & A

- Q: Is Quantum Measurement unitary & reversible?
A: Yes, if the environment is included.
- Q: Does the wavefunction really “collapse”?
A: No. It's all unitary evolution.
- Q: Are RNG outputs really random & causeless?
A: No. They are influenced by future dependencies.
- Q: Can Future events influence the Present?
A: Yes! But usually only in small ways.
- Q: Does God play dice?
A: No! Nothing is fundamentally “random”.

Shoup & Etter – AAAS, June '06

Boundary Institute

Summary Q & A - II

- Q: Are psi phenomena possible/real?
A: Yes. The evidence is quite strong.
- Q: Does psi require rewriting physics?
A: No, just some modest changes to QM formalism.
- Q: Why isn't there more psi?
A: Because we're on a steep statistical slope.
- Q: Can “random” processes be influenced?
A: Yes. The evidence is strong & theory predicts it.
- Q: Can these effects be made large & controllable?
A: Yes, but it requires manipulating many particles.

Shoup & Etter – AAAS, June '06

Boundary Institute

Boundary Institute

www.boundary.org

shoup@boundary.org

etter@boundary.org